

2" x 1"  
DIAMOND MAT, RADIAL TREAD OR  
SQUARE / RECTANGULAR BLOCK  
1/8" DEEP

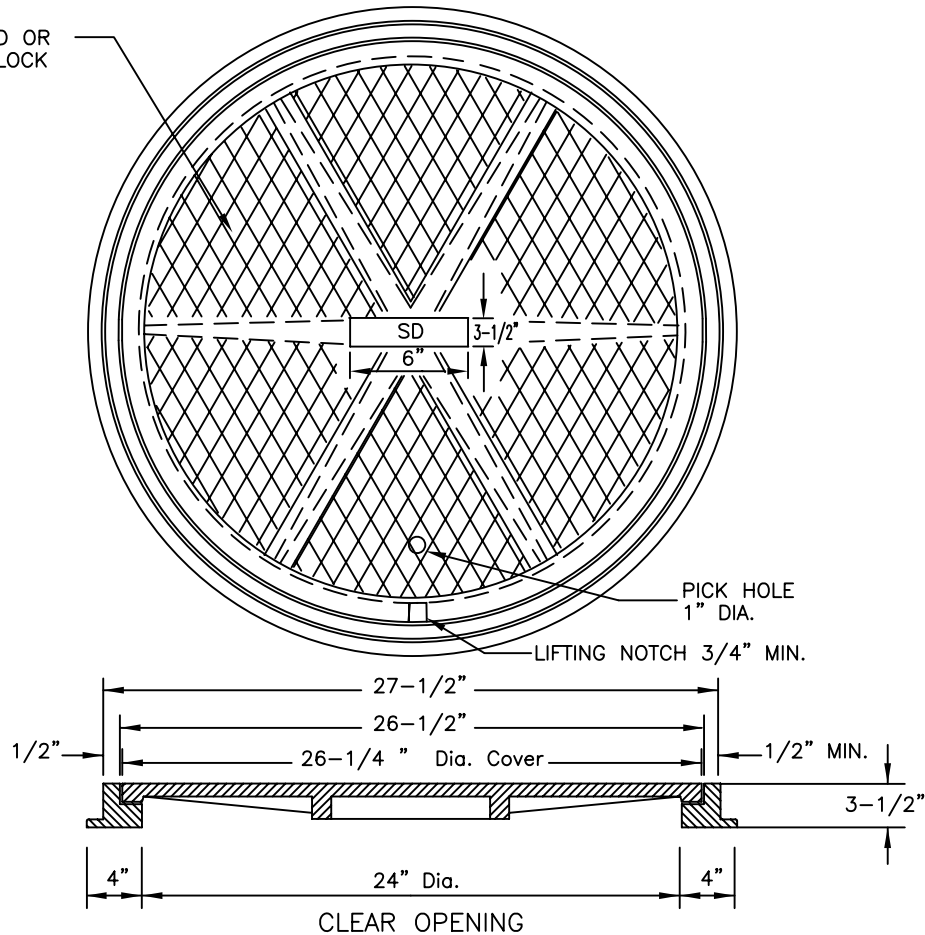
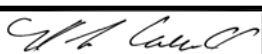

NOTES:

1. THE CAST IRON USED SHALL CONFORM TO ASTM A-48 CLASS 35B AND THE MANHOLE COVER OR RING SHALL NOT BE PAINTED. PROOF-LOAD TEST FOR METHOD "B" IS 40,000 LBS.
2. COVERS SHALL BE CAST WITH THE LETTER "SD" (2" MIN. HEIGHT) FOR STORM DRAINS.
3. FOUNDRY IDENTIFYING MARK/NAME, SHALL BE CAST ON THE TOP OF THE COVER. IMPORTED COVERS AND FRAMES SHALL HAVE THE COUNTRY OF ORIGIN MARKING ON THE TOP OF COVER AND ON THE FRAME IN COMPLIANCE WITH FEDERAL REGULATIONS.
4. FOUNDRY IDENTIFYING MARK/NAME, HEAT AND DATE SHALL BE CAST ON THE BOTTOM OF THE COVER AND ON THE INSIDE OF THE FRAME. IMPORTED COVERS AND FRAMES SHALL HAVE THE COUNTRY OF ORIGIN MARKING ON THE TOP OF COVER AND ON THE FRAME IN COMPLIANCE WITH FEDERAL REGULATIONS.
5. WEIGHT OF FRAME SHALL BE 160 LBS.  
WEIGHT OF COVER SHALL BE 155 LBS.  
ACTUAL WEIGHTS SHALL BE WITHIN A RANGE OF 95% TO 110%.
6. USE ONE OF THE FOLLOWING APPROVED PRODUCTS:  
ALHAMBRA FOUNDRY A-1254-4,  
NEENAH FOUNDRY - NFI-1593  
OR APPROVED EQUAL.
7. REQUEST FOR APPROVED EQUAL WILL REQUIRE THE FOLLOWING:
  - (a) A CERTIFICATE OF COMPLIANCE STATING THAT THE FURNISHED FRAME(S) AND COVER(S) COMPLY IN ALL RESPECTS WITH THE REQUIREMENTS OF THE ABOVE SPECIFICATIONS. SUCH CERTIFICATES SHALL CLEARLY IDENTIFY THE FRAME AND COVER AND BE SIGNED BY THE MANUFACTURER.
  - (b) MANHOLE FRAME(S) AND COVER(S) PRODUCED OUTSIDE THE UNITED STATES SHALL BE FURNISHED WITH A CERTIFICATE OF COMPLIANCE ALONG WITH COMPLETE COPIES OF ALL TESTS AND TEST RESULTS IN COMPLIANCE WITH APWA TEST REQUIREMENTS. THE CERTIFICATE SHALL BE ISSUED BY A PRIVATE TESTING FIRM LOCATED WITHIN CALIFORNIA AND WILL BE AT NO ADDITIONAL EXPENSE TO THE CITY OF IRVINE. THE TESTING FIRM SHALL BE EXPERIENCED AND KNOWLEDGEABLE OF THE TESTING OF MANHOLE FRAMES AND COVERS.

REVISIONS	CITY OF IRVINE	STANDARD PLAN No.
	<b>(24") TRAFFIC MANHOLE FRAME AND COVER</b>	<b>311</b>
	 Approved by: Mark L. Carroll R.C.E. 31515 City Engineer	Sheet 1 of 3
	Date: 03-19-2009	

2" x 1"  
DIAMOND MAT, RADIAL TREAD, OR  
SQUARE / RECTANGULAR BLOCK  
1/8" DEEP

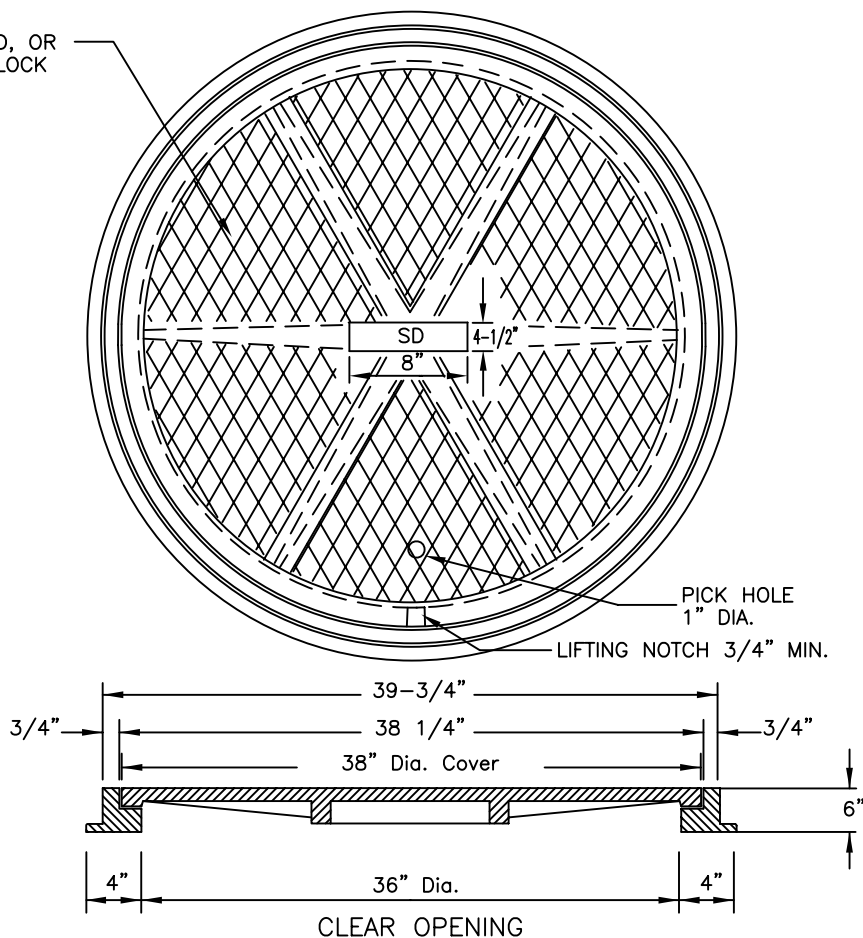

NOTES:

1. THE CAST IRON USED SHALL CONFORM TO ASTM A-48 CLASS 35B. PROOF-LOAD FOR TEST METHOD "B" IS 41,000LBS.
2. COVERS SHALL BE CAST WITH THE LETTER "SD" (3" MIN. HEIGHT) FOR STORM DRAINS.
3. FOUNDRY IDENTIFYING ID#/NAME, SHALL BE CAST ON THE TOP OF THE COVER. IMPORTED COVERS AND FRAMES SHALL HAVE THE COUNTRY OF ORIGIN MARKING ON THE TOP OF COVER AND ON THE FRAME IN COMPLIANCE WITH FEDERAL REGULATIONS.
4. FOUNDRY IDENTIFYING ID#/NAME, HEAT AND DATE SHALL BE CAST ON THE BOTTOM OF THE COVER AND ON THE INSIDE OF THE FRAME. IMPORTED COVERS AND FRAMES SHALL HAVE THE COUNTRY OF ORIGIN MARKING ON THE TOP OF COVER AND ON THE FRAME IN COMPLIANCE WITH FEDERAL REGULATIONS.
5. WEIGHT OF FRAME SHALL BE 300 LBS.  
WEIGHT OF COVER SHALL BE 335 LB..  
ACTUAL WEIGHTS SHALL BE WITHIN A RANGE OF 95% TO 110%.
6. USE ONE OF THE FOLLOW APPROVED PRODUCTS:  
ALHAMBRA FOUNDRY A-1251-6,  
NEENAH FOUNDRY NFI-1739-B,  
OR APPROVED EQUAL.
7. REQUEST FOR APPROVED EQUAL WILL REQUIRE THE FOLLOWING:
  - (a) A CERTIFICATE OF COMPLIANCE STATING THAT THE FURNISHED FRAME(S) AND COVER(S) COMPLY IN ALL RESPECTS WITH THE REQUIREMENTS OF THE ABOVE SPECIFICATIONS. SUCH CERTIFICATES SHALL CLEARLY IDENTIFY THE FRAME AND COVER AND BE SIGNED BY THE MANUFACTURER.
  - (b) MANHOLE FRAME(S) AND COVER(S) PRODUCED OUTSIDE THE UNITED STATES SHALL BE FURNISHED WITH A CERTIFICATE OF COMPLIANCE ALONG WITH COMPLETE COPIES OF ALL TESTS AND TEST RESULTS IN COMPLIANCE WITH APWA TEST REQUIREMENTS. THE CERTIFICATE SHALL BE ISSUED BY A PRIVATE TESTING FIRM LOCATED WITHIN CALIFORNIA AND WILL BE AT NO ADDITIONAL EXPENSE TO THE CITY OF IRVINE. THE TESTING FIRM SHALL BE EXPERIENCED AND KNOWLEDGEABLE OF THE TESTING OF MANHOLE FRAMES AND COVERS.

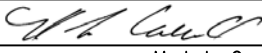
REVISIONS	CITY OF IRVINE	STANDARD PLAN No.
	<b>(36") TRAFFIC MANHOLE FRAME AND COVER</b>	<b>311</b>
	 Approved by: Mark L. Carroll R.C.E. 31515 City Engineer	Sheet 2 of 3
	Date: 03-19-2009	

2" x 1"  
DIAMOND MAT, RADIAL TREAD, OR  
SQUARE/RECTANGULAR BLOCK  
1/8" DEEP

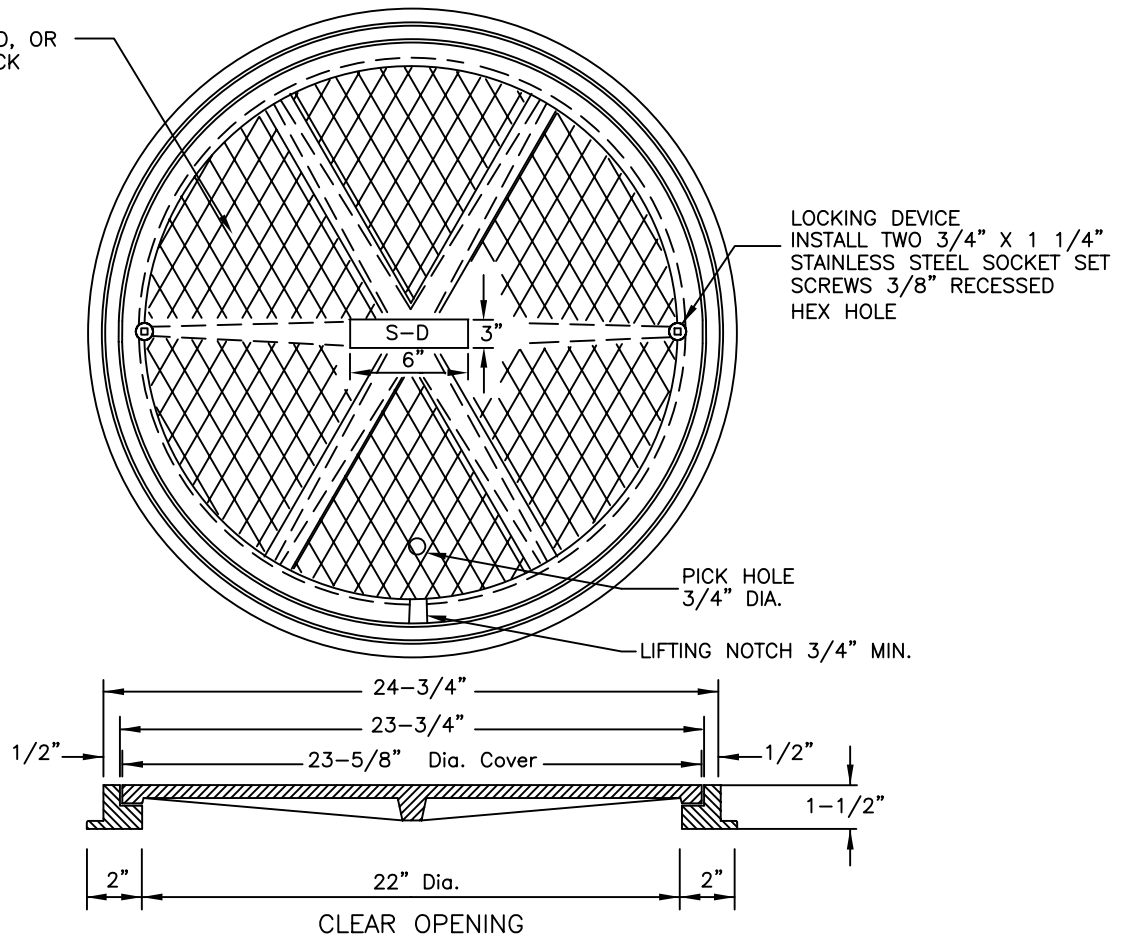

NOTES:

1. THE CAST IRON USED SHALL CONFORM TO ASTM A-48 CLASS 35B. PROOF-LOAD FOR TEST METHOD "B" IS 28,600 LBS.
2. COVERS SHALL BE CAST WITH THE LETTER "S-D" (1" MIN. HEIGHT) FOR STORM DRAINS.
3. FOUNDRY IDENTIFYING ID#/NAME, SHALL BE CAST ON THE TOP OF THE COVER. IMPORTED COVERS AND FRAMES SHALL HAVE THE COUNTRY OF ORIGIN MARKING ON THE TOP OF COVER AND ON THE FRAME IN COMPLIANCE WITH FEDERAL REGULATIONS.
4. FOUNDRY IDENTIFYING ID#/NAME, HEAT AND DATE SHALL BE CAST ON THE BOTTOM OF THE COVER AND ON THE INSIDE OF THE FRAME. IMPORTED COVERS AND FRAMES SHALL HAVE THE COUNTRY OF ORIGIN MARKING ON THE TOP OF COVER AND ON THE FRAME IN COMPLIANCE WITH FEDERAL REGULATIONS.
5. WEIGHT OF FRAME SHALL BE 30 LBS.  
WEIGHT OF COVER SHALL BE 100 LBS.  
ACTUAL WEIGHTS SHALL BE WITHIN A RANGE OF 95% TO 110%.
6. USE ONE OF THE FOLLOWING APPROVED PRODUCTS:  
ALHAMBRA FOUNDRY A-1530-B (GALVANIZED),  
NEENAH FOUNDRY NFI-1579 (GALVANIZED),  
OR APPROVED EQUAL WITH LOCKING DEVICE.
7. REQUEST FOR APPROVED EQUAL WILL REQUIRE THE FOLLOWING:
  - (a) A CERTIFICATE OF COMPLIANCE STATING THAT THE FURNISHED FRAME(S) AND COVER(S) COMPLY IN ALL RESPECTS WITH THE REQUIREMENTS OF THE ABOVE SPECIFICATIONS. SUCH CERTIFICATES SHALL CLEARLY IDENTIFY THE FRAME AND COVER AND BE SIGNED BY THE MANUFACTURER.
  - (b) MANHOLE FRAME(S) AND COVER(S) PRODUCED OUTSIDE THE UNITED STATES SHALL BE FURNISHED WITH A CERTIFICATE OF COMPLIANCE ALONG WITH COMPLETE COPIES OF ALL TESTS AND TEST RESULTS IN COMPLIANCE WITH APWA TEST REQUIREMENTS. THE CERTIFICATE SHALL BE ISSUED BY A PRIVATE TESTING FIRM LOCATED WITHIN CALIFORNIA AND WILL BE AT NO ADDITIONAL EXPENSE TO THE CITY OF IRVINE. THE TESTING FIRM SHALL BE EXPERIENCED AND KNOWLEDGEABLE OF THE TESTING OF MANHOLE FRAMES AND COVERS.

REVISIONS	CITY OF IRVINE	STANDARD PLAN No.
	<b>(22") PARKWAY MANHOLE FRAME AND COVER</b>	<b>311</b>
	 Approved by: Mark L. Carroll R.C.E. 31515 City Engineer	Date: 03-19-2009
		Sheet 3 of 3